



OPERATIONARROWQUIP

THE MAJOR

HYDRAULIC CATTLE CHUTE

[3S - MAJ]

PRODUCT MANUAL

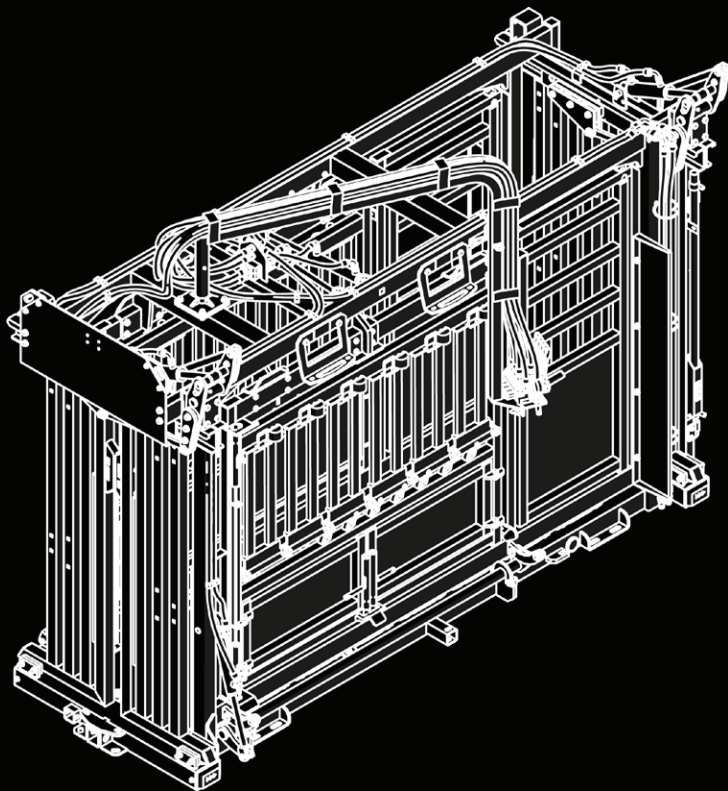

CONTENTS

Safety Precautions	3
Risk Assessment	4
The Major Hydraulic Cattle Chute Assembly	5
Gas Power Pack	6
Electric Power Pack	7
Operating The Major Hydraulic Cattle Chute	8
Potential Pinch Points	9
Cold Start	10
Power Failure	10
Recommended Maintenance	11
Maintenance Safety	11
Regular Maintenance	11
Hydraulic Maintenance	13
Troubleshooting Guide	14
Squeeze Chute	14
Power Pack Troubleshooting	15
Issue: Gas Power Pack Issues	15
Issue: Gas Power Pack start cord is difficult to pull	16
Issue: Pump is not building pressure	16
Issue: Issues with Electric Power Pack	16
10,000 Head Inspection Checklist	16
Warranty	21
Add-Ons Maintenance & safety Precautions	22
Sheeted Sternum Bar	22
Calf Restrainer Bar	23
Hydraulic Neck Extenders	25
Portable Wheel Kit	25
Wheel Maintenance	34



WARNINGS

DO NOT repair the chute or go into the chute when hydraulics are in operation. This can result in injury to the worker. Disconnect the power source before performing any necessary repairs or inspection.

DO NOT ATTEMPT TO CONNECT THE ELECTRIC POWER PACK IF YOU ARE NOT A CERTIFIED ELECTRICIAN. For your safety, electric power packs must be connected and wired by a fully certified electrician.

There are a number of pinch points to be aware of on The Major, including the Head Gate, Tail Gate, Rump Bar, Side Exit Door, and Fork Targets. Please exercise caution when working with the equipment to avoid injury to the operator and livestock.

HYDRAULIC LIFT AND WHEEL KIT WARNINGS & SAFETY PRECAUTIONS

Wheel Kit Warning & Safety Precautions

- When chute is not attached to vehicle, lower front hitch jack to the ground for safety.
 - Always lower unit to the ground immediately when transport is complete.
 - Wheel nuts / bolts should be torqued before first road use and after each wheel removal.
-

PLEASE FOLLOW ALL SAFETY INSTRUCTIONS PROVIDED IN THIS MANUAL BEFORE OPERATION. ARROWQUIP DOES NOT ACCEPT RESPONSIBILITY FOR ANY ACCIDENTS OR INJURY WHEN THIS SAFETY MANUAL HAS NOT BEEN READ IN FULL AND KEPT WITH THE PRODUCT AT ALL TIMES. OPERATORS OF THIS PRODUCT TAKE AND ACCEPT RESPONSIBILITY FOR ANY HARM OR INJURY TO THE ANIMAL OR OPERATOR WHEN IT PERTAINS TO HOW THE EQUIPMENT IS USED AND MAINTAINED.

Please keep this manual for frequent reference and to pass on to new users or owners

SAFETY PRECAUTIONS

PLEASE FOLLOW ALL SAFETY PRECAUTIONS OUTLINED HEREIN. ANY HARM TO THE ANIMAL OR INJURY TO THE OPERATOR WHICH OCCURS DUE TO HOW THE PRODUCT IS OPERATED, OR RESULTING FROM A LACK OF SAFETY PRECAUTIONS ARE THE SOLE RESPONSIBILITY OF THE OPERATOR.

All farm machinery and equipment are potentially dangerous. Careless use of any Arrowquip livestock equipment may cause injury or damage to persons, cattle, or property. Arrowquip has taken precautions in the design and manufacturing of this product to ensure that it is safe and user-friendly. Therefore, user must assume all responsibility and risk associated with the possession and use of the equipment.



WARNING: READ BELOW BEFORE OPERATION.

Ensure the operator understands the contents of this manual before using the cattle squeeze chute.

- 1. DO NOT** wear loose-fitted clothing.
2. Ensure the cattle squeeze chute is on a firm, level, dry surface that is free of rocks and other trip hazards. A level concrete pad flush with the ground and with the chute bolted to the concrete is strongly recommended.
- 3. DO NOT** enter the vet cage until the animal is secured in the head gate and the rump bar has been placed behind the animal so that the cow cannot back up.
- 4. DO NOT** stand in front of the head gate while operator is moving the cattle through the squeeze chute.

5. DO NOT ALLOW CHILDREN UNDER THE AGE OF 18 NEAR AN OPERATING MACHINE.

6. Follow safe cattle handling procedures in other areas of the yard so that cattle are more docile in the chute.

7. DO NOT make any modifications to Arrowquip equipment. Non-factory modifications to the equipment can reduce the safety for the operator & livestock, and void warranty.

8. DO NOT ALLOW CHILDREN UNDER THE AGE OF 18 TO USE THE HYDRAULIC EQUIPMENT.

9. DO NOT OPERATE HYDRAULICS WHILE OPERATORS ARE WORKING WITH THE CATTLE IN THE CHUTE OR ARE TOUCHING THE CHUTE. REACHING OUT OR INTO THE CHUTE WHILE HYDRAULICS ARE IN OPERATION CAN RESULT IN SERIOUS INJURY.

10. Please ensure that all hydraulic hoses and electrical leads are out of the way and safely positioned before moving cattle or using the chute.

11. Keep a distance of more than an arm's length from the hydraulic chute while hydraulics are in operation.

12. When using the Emergency Side Exit, exercise caution. Improper placement of the swing arm may result in injury to the operator or damage to the equipment.

13. When using V-Squeeze setting on small calves, be cautious with the amount of pressure being placed on the animal, specifically the lower squeeze as excessive pressure may cause leg/hoof damage.

14. Stay alert when using side exit doors and bottom swing-out gates on uneven ground or V-Squeeze/A-Squeeze settings, as doors may open/close on their own.

15. When using the drop-down side access panels, ensure the latch is fully engaged to prevent the panels from dropping when under pressure.

16. When closing doors, ensure latching pins move freely, so that they will fully engage in the latch catches and function properly.

RISK ASSESSMENT

Conduct a risk assessment on procedures regarding the operation of an Arrowquip hydraulic squeeze chute, establishing a safe work procedure.

1. Ensure all users of the equipment have been inducted and comply with safe working procedures.
2. Please ensure that the hydraulic chute is secured on firm ground.
3. Please ensure that there are no hydraulic hoses or large objects within or around the chute where cattle and operator will be.
4. Please ensure that all hydraulics work properly before putting cattle through the chute.

5. Please make sure that all hydraulic hoses are properly secured to the power pack or tractor hook up.
6. Ensure that the hydraulic controls are functioning properly. Specifically ensure that the adjustable side mechanism and the head gate are adjusting smoothly.
7. If hydraulics do not function properly when testing the equipment, **DO NOT** put cattle through the chute.
8. Ensure that access gates are closed securely before running cattle through the chute.
9. Some chemicals and medicines can damage powder coat. Take all precautions and wash after use.
10. Make sure your chute has been cleared of ALL livestock after use.

THE MAJOR HYDRAULIC CATTLE CHUTE ASSEMBLY



DO NOT ATTEMPT TO CONNECT THE ELECTRIC POWER PACK IF YOU ARE NOT A CERTIFIED ELECTRICIAN.

Your chute will come fully assembled with the options you have ordered already fitted to the chute. However, it will be necessary to connect the hydraulic hoses to a tractor or power pack. The following guide will assist you in properly setting up your chute for use.

SETTING UP THE MAJOR HYDRAULIC CATTLE CHUTE

1. Hydraulics are plug and play. Please ensure that the color code of the hoses matches to the quick connects. Rule of thumb: red is pressure, black is tank.
2. When hooking up the hoses, ensure the couplers are engaged and the female sleeve is snapped into place.
3. Engage oil recirculation by pulling up on the valve knob to warm oil before use.
4. Start motor by following starting procedure.
5. When shutting down, engage oil recirculation again and shut gas engine off.

GAS POWER PACK

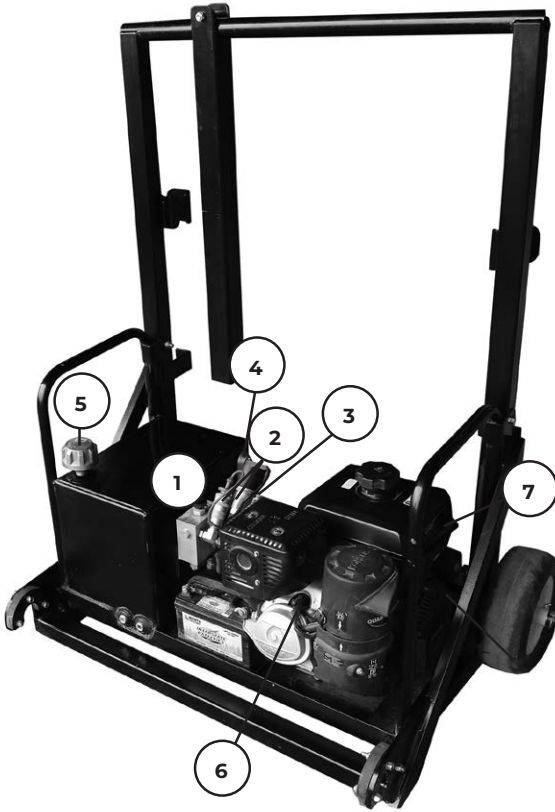

1. Recirculation Valve
2. Quick Connect Ports
3. Oil Filter
4. Oil Level Sight Glass
5. Breather Fill Cap
6. Engine Oil Plug
7. Starter Pull Cord



DO NOT START GAS ENGINE WITHOUT CONNECTING PRESSURE AND TANK HOSES TO UNIT. DAMAGE MAY OCCUR IF RECIRCULATION VALVE IS NOT ENGAGED.

1. Open recirculation valve.
2. Open fuel shut off valve.
3. Ensure choke is fully engaged.
4. Pull starter handle to start engine.
5. Run engine on choke for 5-10 seconds.
6. Shut choke off completely.
7. Run engine with hydraulic oil recirculating for 5-10 minutes depending on ambient temperature.
8. Open recirculation valve and chute is ready to operate.

ELECTRIC POWER PACK



DO NOT ATTEMPT TO CONNECT THE ELECTRIC POWER PACKS IF YOU ARE NOT A CERTIFIED ELECTRICIAN.

For your safety, electric power packs must be connected and wired by a fully certified electrician.

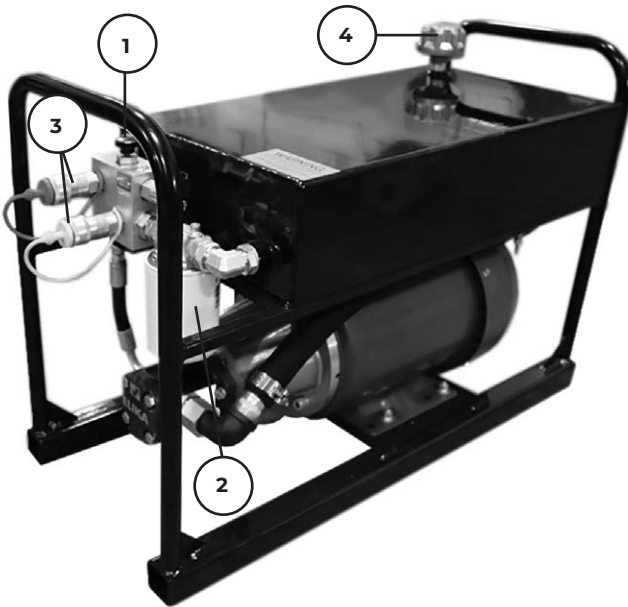

1. Recirculation Valve
2. Oil Filter
3. Quick Connect Ports
4. Breather Fill Cap

7.5HP STEALTH ELECTRIC POWER PACK

If you have any questions, contact Arrowquip Client Care at 1-877-275-6075.



**MUST BE CONNECTED BY A CERTIFIED ELECTRICIAN.
CONTACT 1-877-275-6075 WITH ANY QUESTIONS.**

VIEW FROM OUTSIDE OF MOTOR AT SWITCH END.

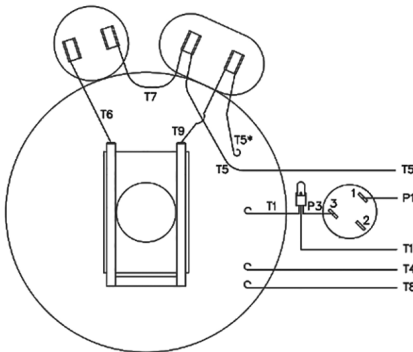

* THIS LEAD MAY BE WHITE

LINE LEADS

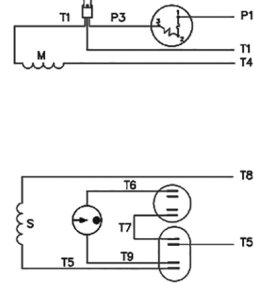

ROTATION FACING LEAD END	L1	L2	JOIN
C.W.	P1	T4, T8	T1, T5

		DIMENSIONS UNLESS SPECIFIED		LEESON	ELECTRIC MOTORS GEARMOTORS AND DRIVES	DRAWN NLW 06/30/76			
		DEC.	INCHES				CHK	WRK	
08	ALTERNATE T5 LEAD MARKING WAS RED	RLW	8/8/02	JX	±.1	APPD			
07	ADDED ALTERNATE T5 LEAD MARKING	RLW	5/31/02	KH	±.001	SCALE 1=1			
06	REDRAWN TO CAD	DST	5/31/02	JXXX	±.0005	REF			
NO.	REVISION	BY & DATE	CHK	ANG	±1/2"	FINISH			
THIS DRAWING IN DESIGN AND DETAIL IS OUR PROPERTY AND MUST NOT BE USED EXCEPT IN CONNECTION WITH OUR WORK. ALL RIGHTS OF DESIGN AND INVENTION ARE RESERVED. THIS IS AN ELECTRONICALLY GENERATED DOCUMENT - DO NOT SCALE THIS PRINT				REP	CAD FILE	00505603	SIZE	DRAWING NO.	REV.
02/22/2008 4:52:22 PM				DST	BRF-NLV		A	005056-03	08



**DO NOT CONNECT MOTOR TO POWER SOURCE
WITHOUT CONNECTING PRESSURE AND TANK HOSES
TO UNIT. SEVERE DAMAGE MAY OCCUR.**

OPERATING THE MAJOR HYDRAULIC CATTLE CHUTE

STOP

**ENSURE ALL CHUTE FUNCTIONS AND ADD-ONS ARE
WORKING PROPERLY BEFORE OPERATING.**

1. Ensure all access points are closed before the animal enters the chute.
2. Open tail gate for the animal to enter the squeeze chute enclosure.
3. Close tail gate.

STOP

TIP FOR CATCHING CATTLE: ENSURE THE HEAD GATE IS SECURED INTO THE HOLLOW OF THE ANIMALS NECK TO ALLOW FOR PROPER OPERATION OF THE NECK EXTENDERS.

4. Open head gate slightly more than the neck size of the animal to tempt the animal to stick its head through the head gate. When neck of animal is in the correct position, quickly close the head gate securely on the animal's neck.
5. If required, side squeeze animal and engage head restraint (if equipped) to restrain further movement.
6. If the animal applies excessive pulling pressure on head gate, it is recommended to use the anti-backing bar behind cattle rump.

STOP

CONFIRM ANIMAL IS SECURELY HELD BEFORE CARRYING OUT ANY HUSBANDRY WORK.

POTENTIAL PINCH POINTS

- Head Gate
- Tail Gate
- Rump Bar Access
- Side Exit Door
- Fork Targets

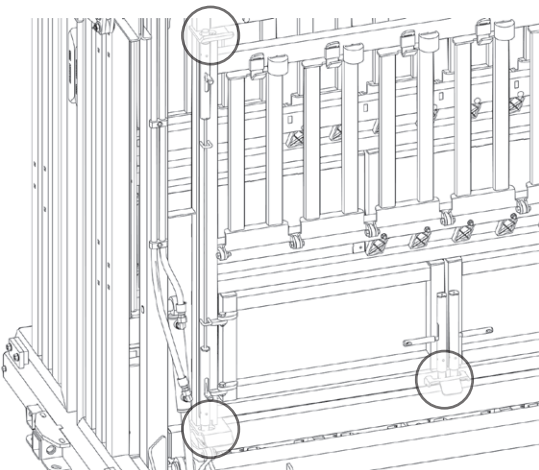

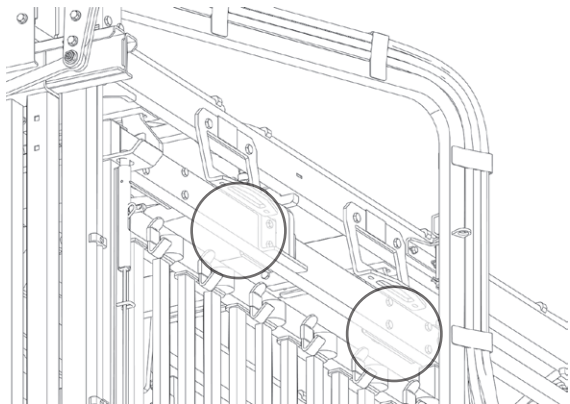

COLD START

To cold start the unit it when it is not at operating temperature, follow the below instructions.

1. With recirculation valve locked in the up position, the cold start allows the oil to circulate within the power pack to warm the oil, allowing for faster flow rate to the chute.
2. With recirculation valve locked in the down position, it is engaged to run the chute.

POWER FAILURE

If you should experience a loss of power while you have an animal in the chute, please follow the instructions below:

1. Operate the hydraulic levers to release pressure in the hydraulic circuit and allow fluid to flow out of the cylinders, therefore releasing pressure on the animal.
2. With the levers engaged, pull on the Head Gate Door / Squeeze Panel to open the door if necessary.
3. Check to make sure that the animal is free of any injury.
4. Release the animal from the chute.
5. Review the cause for power failure and troubleshoot to restore power.
6. See start-up procedure once power is restored.

RECOMMENDED MAINTENANCE

Before doing **ANY** work or troubleshooting on your hydraulic chute, contact Arrowquip Client Care at 1-877-275-6075.

MAINTENANCE SAFETY

1. Ensure the area is clear of bystanders, especially children, when doing any maintenance or repair on the hydraulic squeeze chute.
2. Keep all body parts, including hair, hands, feet, etc., away from the machine when hydraulics are in operation.
3. Before carrying out any maintenance on the squeeze chute, please ensure there are no livestock in the chute.
4. **DO NOT** repair the chute or go into the chute when hydraulics are in operation or while power pack is running. This can result in injury to the worker. Disconnect the power source before performing any necessary repairs or inspection.

REGULAR MAINTENANCE

- ✓ **Inspect the entire unit.** Ensure all moving components are free of debris and functioning properly. Use proper cleaning and troubleshooting steps, if necessary.
- ✓ Grease cylinders and zerks (8 total).

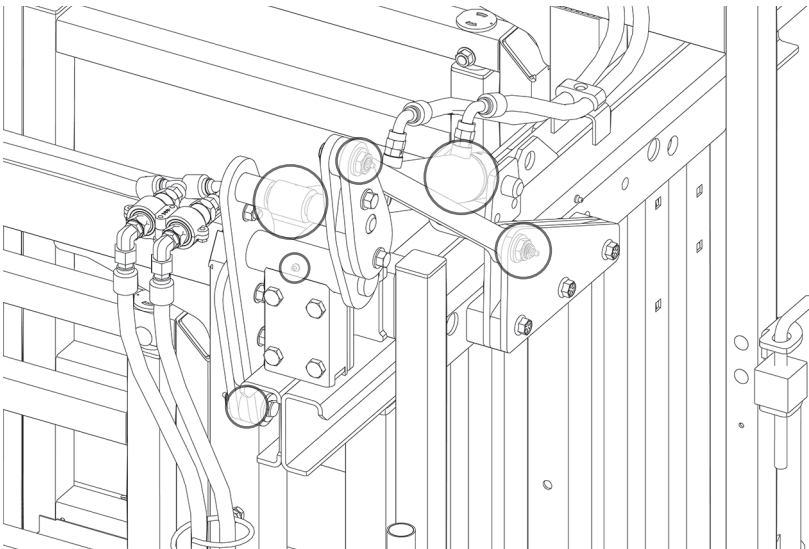

- ✓ Grease squeeze pivots (6x shown 12x total).

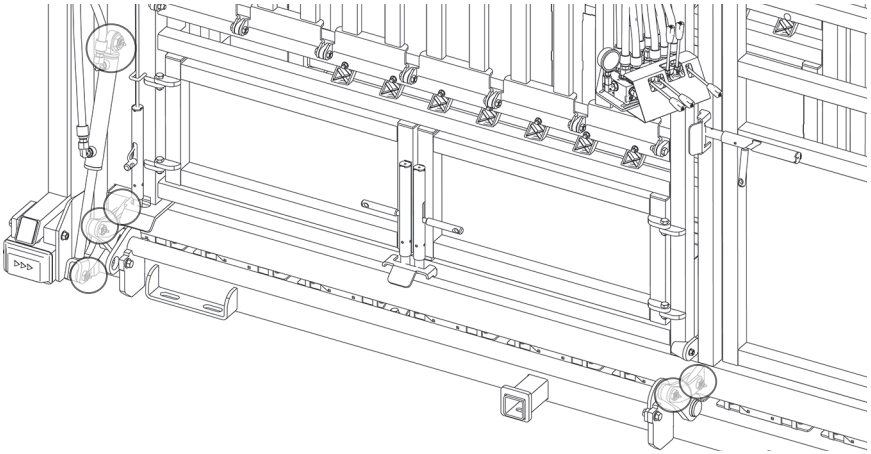

- ✓ Grease head gate linkage and cylinder (7x per head gate 14x total)
- ✓ Lubricate slam latches and door hinges with WD-40 Dry Lube.
- ✓ Check gate latches and striker plates for wear. Ensure gates are locking securely.

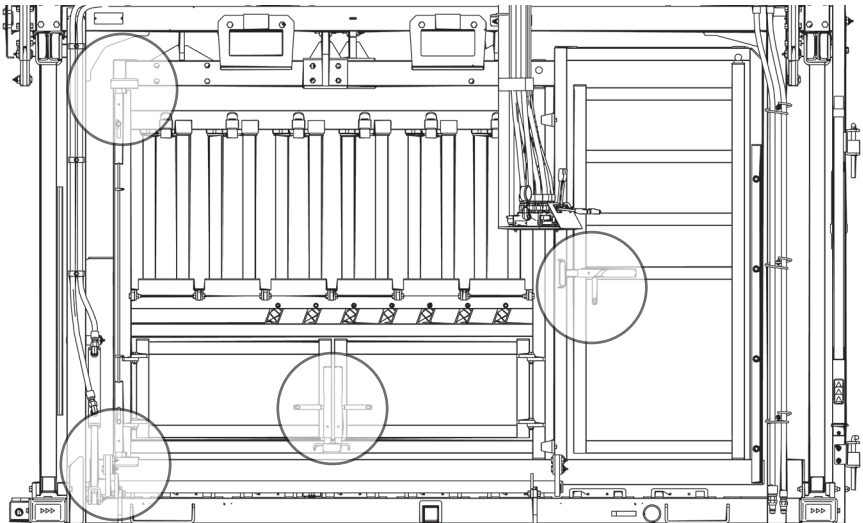

- ✓ Clean bottom head gate door track to prevent dirt-build-up.

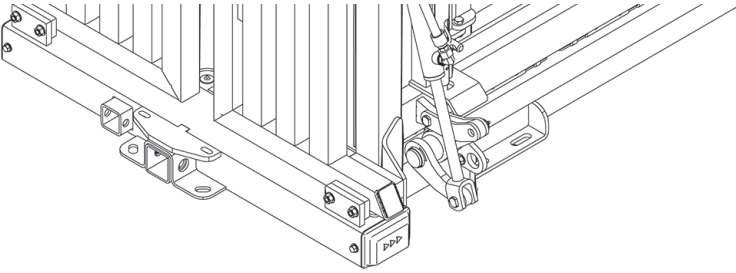

- ✓ Clean the chute floor. Excess build-up of manure or dirt inside chute can cause the squeeze and head gate to malfunction.
- ✓ Check pivot mechanism pins for wear. Lubricate with WD-40 Dry Lube as necessary.
- ✓ Grease pivot point on neck extenders.
- ✓ Grease head gate track (4x shown, 8x total).

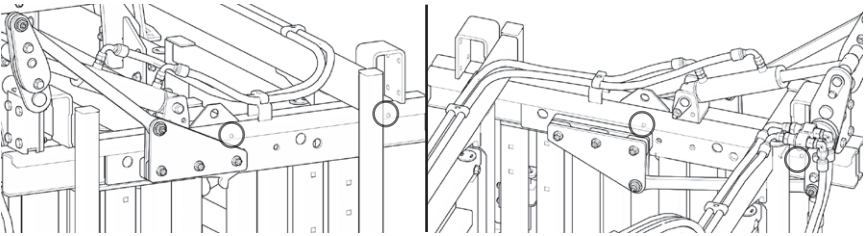

HYDRAULIC MAINTENANCE

Oil Change



1. Replace oil every 6 months or 10,000 head of cattle, or more frequently as necessary.

For chutes that see large numbers of cattle, replace every 3 months.

Follow indicator on the power pack for recommendation.

- a. Use AW22 or HWI-22 oil.



DIRTY OIL OR OIL THAT HAS 0.05% OF WATER IN IT CAN BE CATASTROPHIC FOR HYDRAULIC SYSTEMS. REPLACE OIL FREQUENTLY TO PREVENT DAMAGE TO YOUR HYDRAULIC JACKS AND KEEP THEM WORKING SAFELY AND RELIABLY.

Filter Change

The filter must be replaced with a compatible filter every 2-3 oil changes, or more frequently as necessary. Any of the following filters may be used to replace the existing filter.

- Zinga: AE10 Filter
- Wix: 51551
- Napa: 1551
- Baldwin: BT839-10

To replace the filter, follow the below steps.

1. Unthread and discard old filter.
2. Ensure new filter is not bent or damaged in any way.
3. Clean filter base making sure old gasket is removed. Apply clean oil to new filter gasket. **DO NOT USE GREASE OR ANY OTHER LUBRICANT.**
4. Make sure the gasket is seated. screw filter on to base until contact.
5. Tighten ½ turn, refill and run system. Check oil pressure & check for leaks.

TROUBLESHOOTING GUIDE

Before doing **ANY** work or troubleshooting on your hydraulic chute, contact Arrowquip Client Care at 1-877-275-6075.



DO NOT ATTEMPT TO TROUBLESHOOT OR FIX ISSUES WITH THE ELECTRIC POWER PACK UNLESS YOU ARE A CERTIFIED ELECTRICIAN

SQUEEZE CHUTE

1. To ensure proper operation make sure chute is situated on level ground or base.
2. Make sure head gate door tracks are free of debris.
3. Keep floors clean. Excess build-up of manure or dirt inside chute can cause the squeeze and head gate to malfunction.
4. Lubricate slam latches and pivot points with WD-40 Dry Lube.

POWER PACK TROUBLESHOOTING

ISSUE: GAS POWER PACK ISSUES

Problem	Possible Cause							
	No Fuel	Improper Fuel	Dirt in Fuel Line	Dirty Debris Screen	Incorrect Oil Level	Engine Overloaded	Dirty Air Cleaner	Faulty Spark Plug
Will Not Start	•	•	•		•	•	•	•
Hard Starting		•	•		•	•	•	•
Stops Suddenly	•		•	•	•	•	•	•
Lacks Power		•	•	•	•	•	•	•
Operates Erratically		•	•	•		•	•	•
Knocks or Pings		•		•		•		•
Skips or Misfires		•	•	•			•	•
Backfires		•	•			•	•	•
Overheats		•	•	•	•	•	•	
High Fuel Consumption						•	•	•

For detailed instructions on how to remedy these problems, refer to your Gas Power Pack manual.



ISSUE: GAS POWER PACK START CORD IS DIFFICULT TO PULL

Reference Kohler Power Pack manual for further instructions.

ISSUE: PUMP IS NOT BUILDING PRESSURE

1. Disengage the recirculation valve.
2. Ensure hydraulic lines are properly connected.
3. Change power pack oil if it has not been done recently.
4. If all else fails, call Client Care 1-877-275-6075 for further assistance.

ISSUE: ISSUES WITH ELECTRIC POWER PACK

Contact your Electrician for assistance with any Power Pack issues.
For additional information, contact Arrowquip Client Care at 1-877-275-6075.

10,000 HEAD INSPECTION CHECKLIST

Every 10,000 cattle or every 6 months, whichever comes sooner, review the following parts on the chute to ensure there is no wear taking place.

1. Neck Extender Pin Connections
 - a. 12 connection points

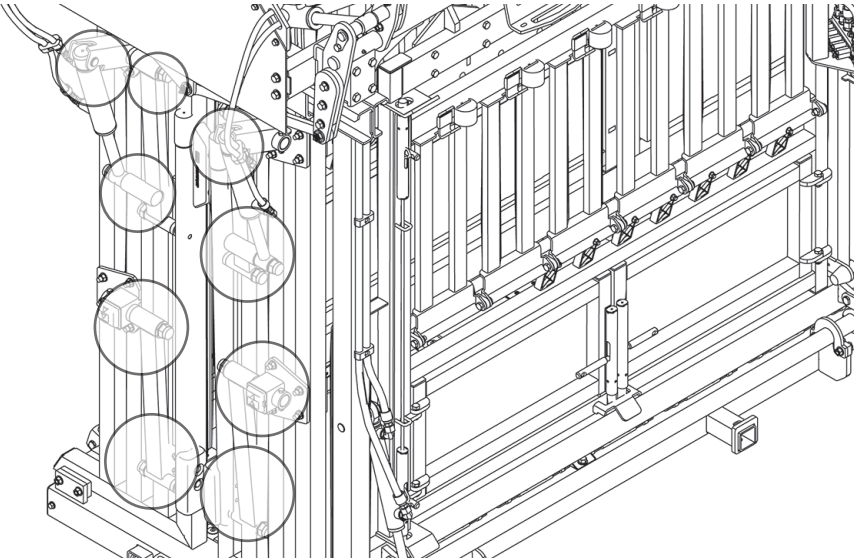

2. Torsion Bar Connections

a. 4 connection rotation points

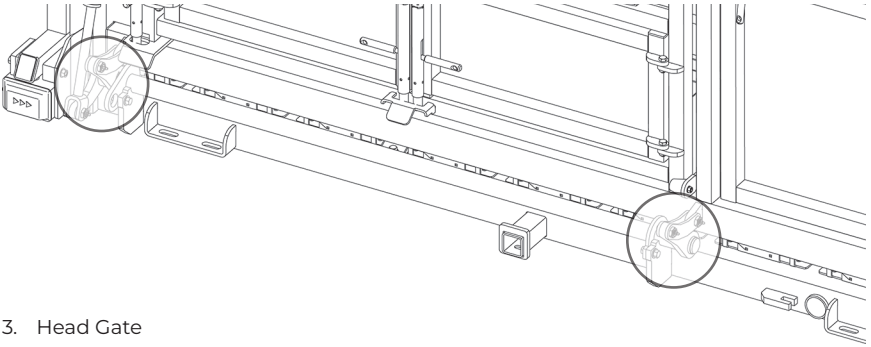

3. Head Gate

a. Inspect roller glides on Head Gate Doors for wear

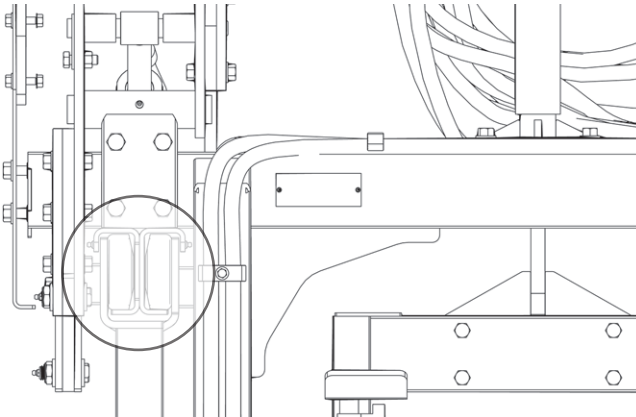

b. Inspect roller glides on the bottom of the Head Gate track for wear

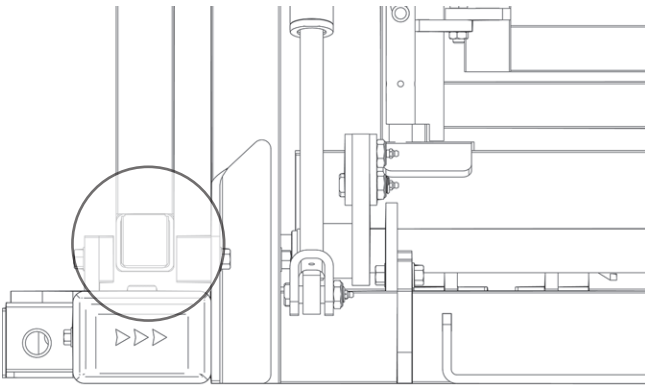

4. Tail Gate

- a. Inspect roller glides on Tail Gate Doors for wear

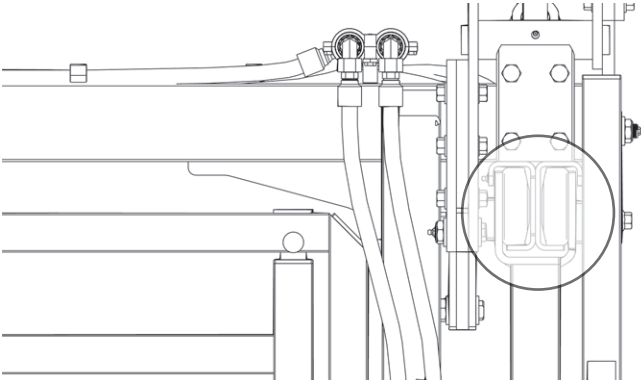

- b. Inspect roller glides on the bottom of the Tail Gate track for wear

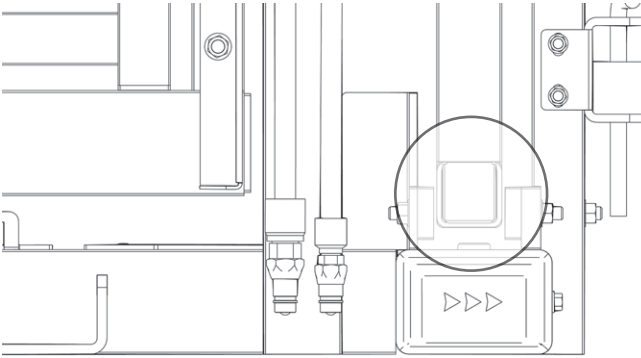

5. Top Squeeze Track

- a. Inspect roller glides on Squeeze Track for wear

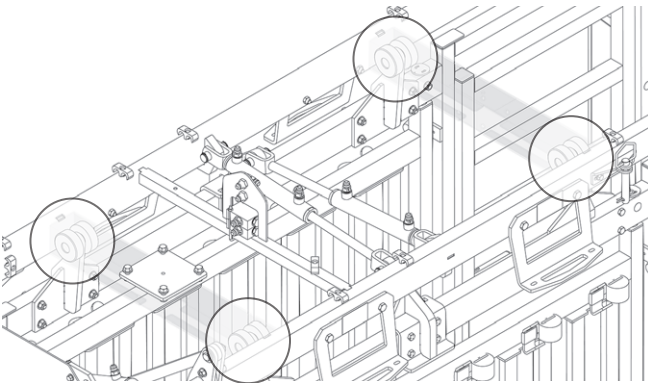

- b. Ensure bolts on the Squeeze Tower are tightened properly (24 total - 12 shown)

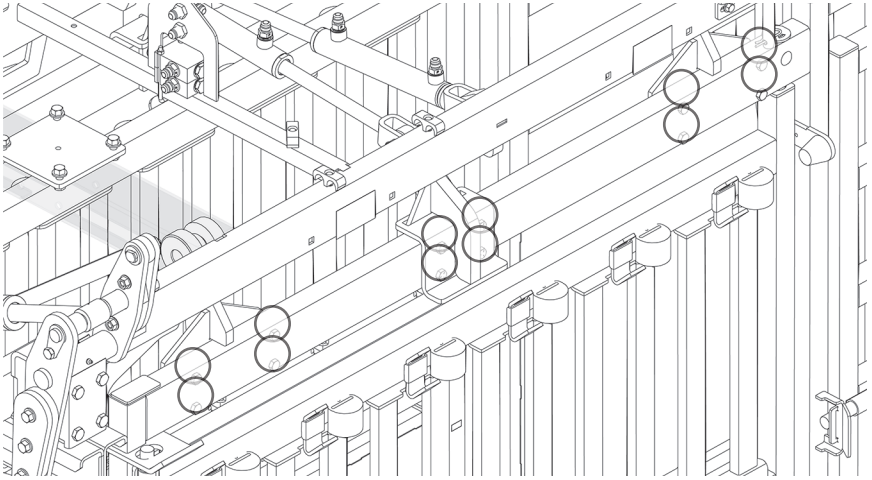

6. Head Gate Cushions

- a. Inspect for wear and ensure they are providing sufficient cushion for the animal

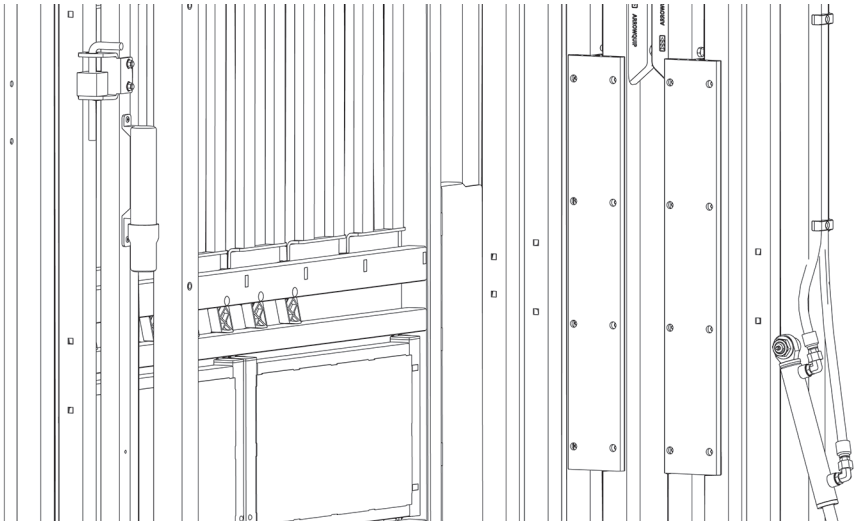

7. Hydraulic Cylinder Pins and Bolts

- a. Inspect for wear and ensure bolts are tightened properly and clips are seated properly

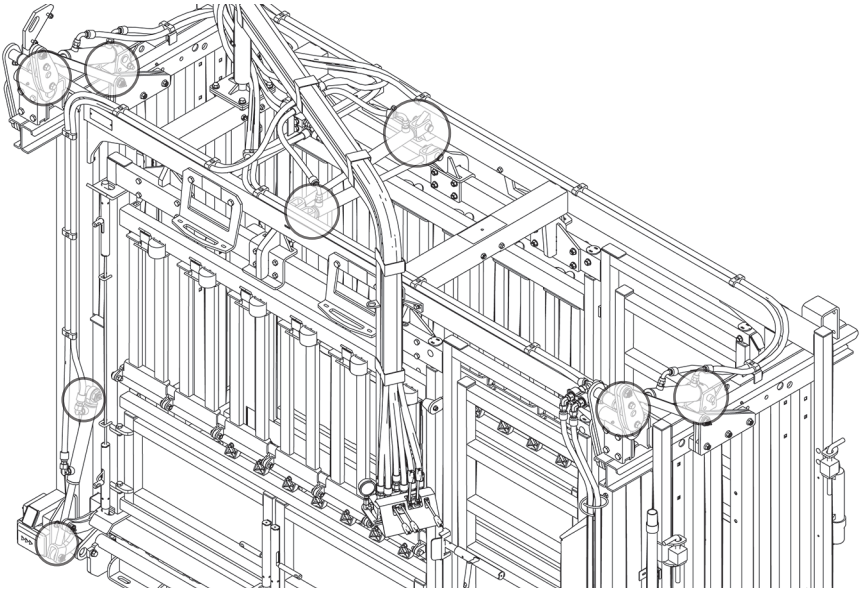

8. Hitch Mount

- a. Inspect for wear

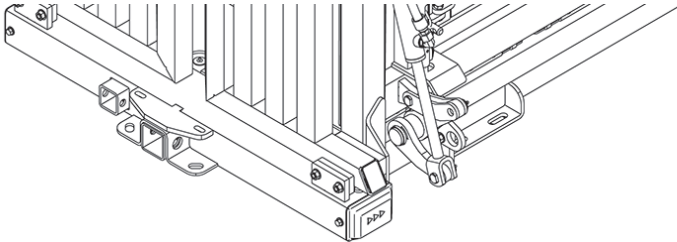

9. Axle Receivers

a. Inspect for wear

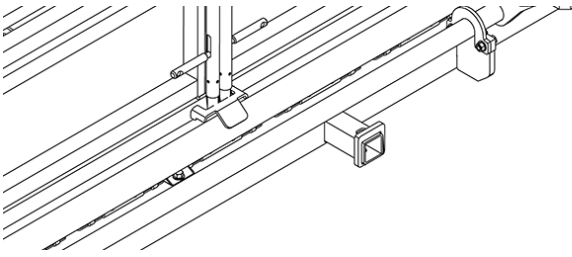

WARRANTY

15 Years **or** 150,000 Total Head of Cattle.*

Your product must be registered to claim warranty, and to ensure that Arrowquip has the required information to contact you in the event of a product or part recall. Any owner who fails to register their product warranty with Arrowquip through their Authorized Arrowquip Dealer voluntarily voids their warranty. Arrowquip will repair or replace products or parts of a product that prove defective due to manufacturer defect during the Warranty Period, at their sole discretion. This excludes defects resulting from normal wear and tear or product misuse. Warranty does not cover corrosion. NOTE: Any modification, in any fashion, to any Arrowquip equipment immediately voids the product warranty. This includes the parts contained therein.

Eg. If a modification is made to the squeeze mechanism in a squeeze chute, and the sternum bar is bent afterwards, warranty for the damaged part, the sternum bar, contained in the modified equipment, the squeeze chute, is void. In addition, any remaining warranty for the squeeze chute and other parts contained therein, including, but not limited to, the head gate, locking system, Q-Catch system, and rollers, is null and void.

REGISTER FOR WARRANTY NOW:

Online: operationarrowquip.com/warranty

Phone: 1-877-275-6075 | **Email:** cs@arrowquip.com

* Warranty valid for the number of years or the number of head outlined above, whichever limit is met first. Follow the recommended use instructions to maximize the lifespan of your equipment. Arrowquip products that have only been used within acceptable tolerance following the stated recommended use will be eligible to claim warranty.

ADD-ONS MAINTENANCE & SAFETY PRECAUTIONS

SHEETED STERNUM BAR

Installation:

1

Insert the sternum bar into the bracket.

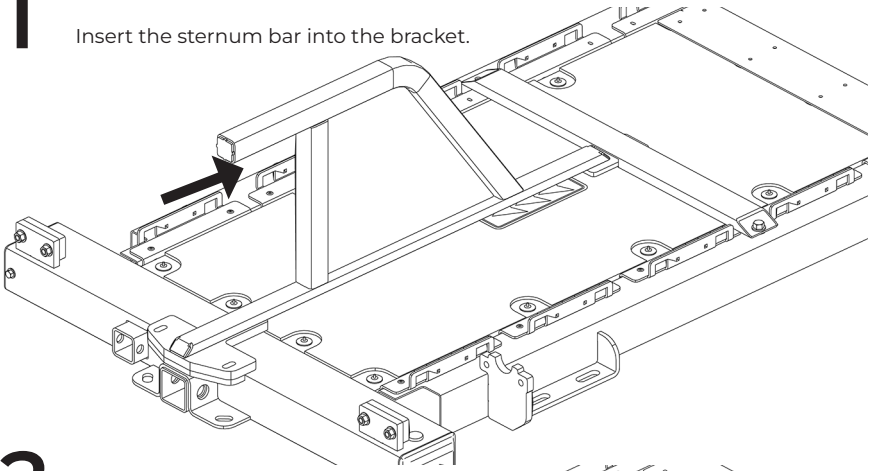

2

Fasten bolts to front plate.

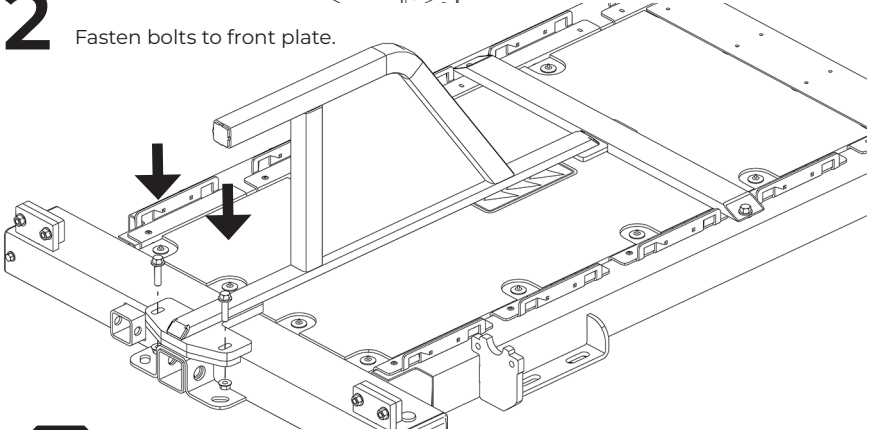

STOP

SAFETY CHECK:

- ✓ Ensure that the sternum bar is installed correctly before running cattle through the chute.

Safety Precautions:

1. Remove the sternum bar when working calves.

TRACTION KIT

NOTE: The Traction Kit comes standard on The Colonel.

Installation:

1

If your chute does not come equipped with the traction kit, please contact our Client Care team to order.



SAFETY CHECK:

- ✓ Ensure that the Traction Kit is installed correctly before running cattle through the chute..

CALF RESTRAINER BAR

Installation:

1

Set the wider end of the calf restrainer bar on the bottom 2x4 of the squeeze frame with the bar facing the inside of the chute.

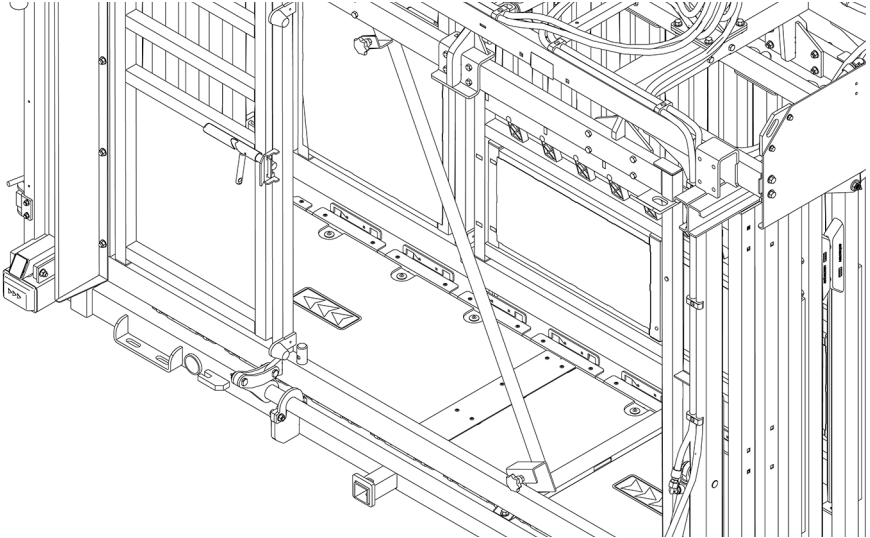

2

Rotate the calf restrainer bar until it is vertical and the top bracket is in place on the top 2x4 of the squeeze frame.

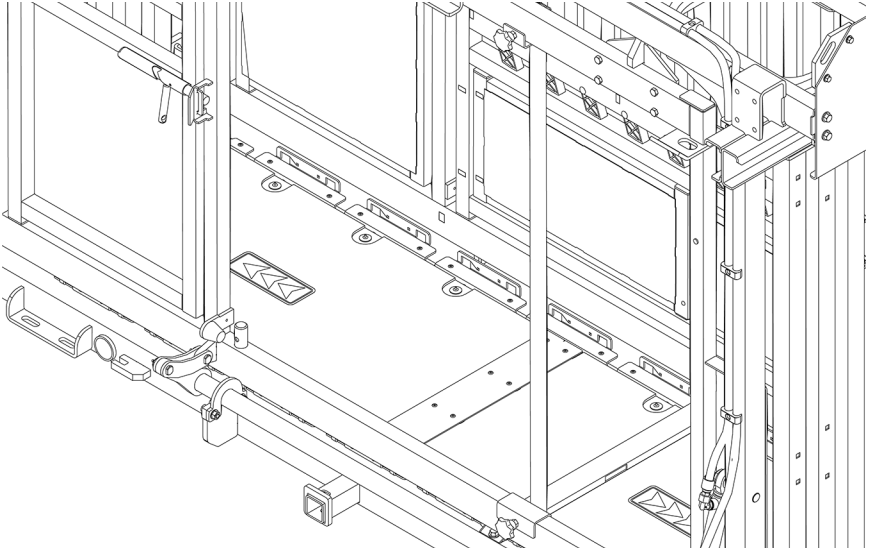

3

Adjust to the desired location and secure the calf restrainer bar in place using the wing bolts.

Safety Precautions:

1. Ensure the calf restrainer bar is installed and secured correctly before running cattle through the chute.

HYDRAULIC NECK EXTENDERS

Installation:

1. If your chute comes with hydraulic neck extenders installed, it is ready for use.
2. If your chute does not come equipped with hydraulic neck extenders, please contact our Client Care team to order.

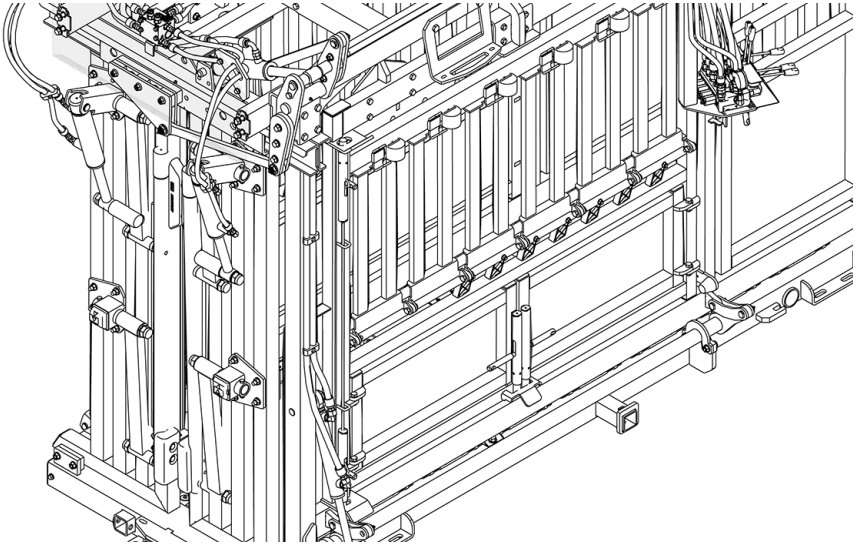

If your neck extenders begin to operate out of sync, fully retract them against the head gate, and hold until both sides are flat against the head gate.

Safety Precautions:

1. Ensure that the hydraulic neck extenders are operating correctly before running cattle through the chute.



WARNING! UNIT WEIGHT WITH NO ACCESSORIES IS APPROXIMATELY 3182 LBS. BEFORE LIFTING THE UNIT WITH OTHER MACHINERY SUCH AS A FORKLIFT, ENSURE THE LIFTING EQUIPMENT HAS ADEQUATE CAPACITY TO LIFT THE UNIT SAFELY.

PORTABLE WHEEL KIT

Requirements:

- Portable Wheel Kit for The Major

PREPARING THE CHUTE FOR TRANSPORT

- 1** Power up the gas power pack.
- 2** Open the tail gate doors and roll the power pack into the chute.
- 3** Close the tail gate and ensure the head gate is also closed.
- 4** Using the side access door or drop-down panels, power off the power pack.
- 5** Disconnect the hoses from the power pack and wrap around the power pack cart for transport.
- 6** Close all side access doors and drop-down panels.

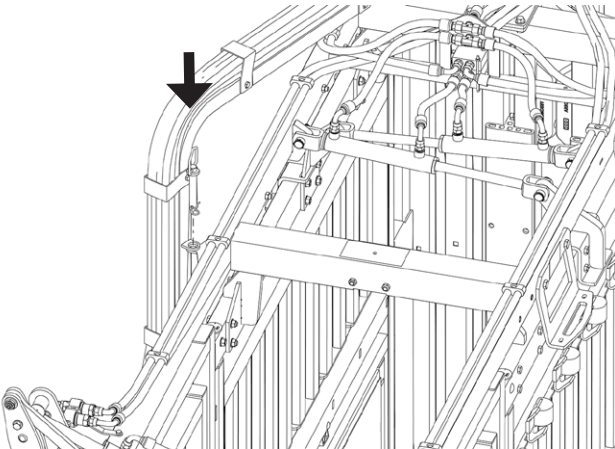

7

Secure hydraulic swing arm using the bracket, pin, and R clip provided.

8

Ensure all gates and doors are closed and slam latches are secured.

WHEEL & HITCH INSTALLATION

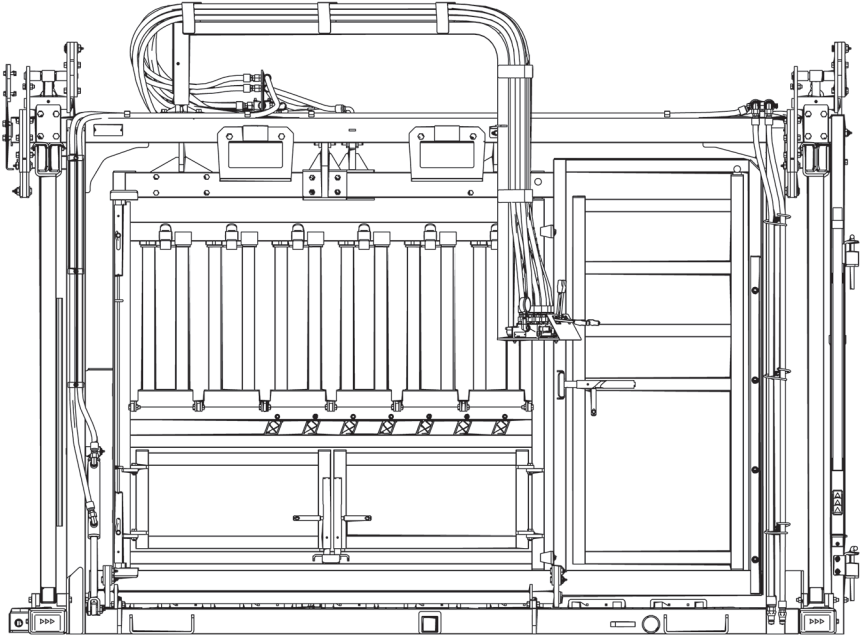

1

Ensure the chute is on level, firm ground.

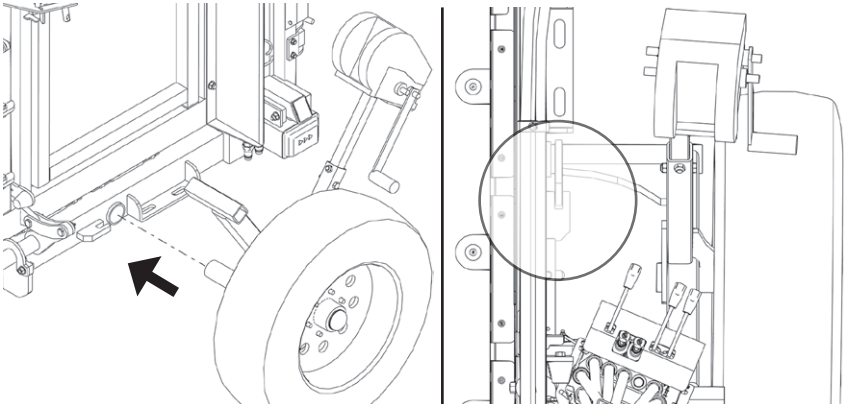

2

Install both wheels into the circular wheel mounts located near the vet cage, ensuring the profiles on the main support bars line up with the slots on the chute wheel mounts.

STOP

BOTH WHEELS MUST BE PROPERLY INSTALLED BEFORE PROCEEDING.

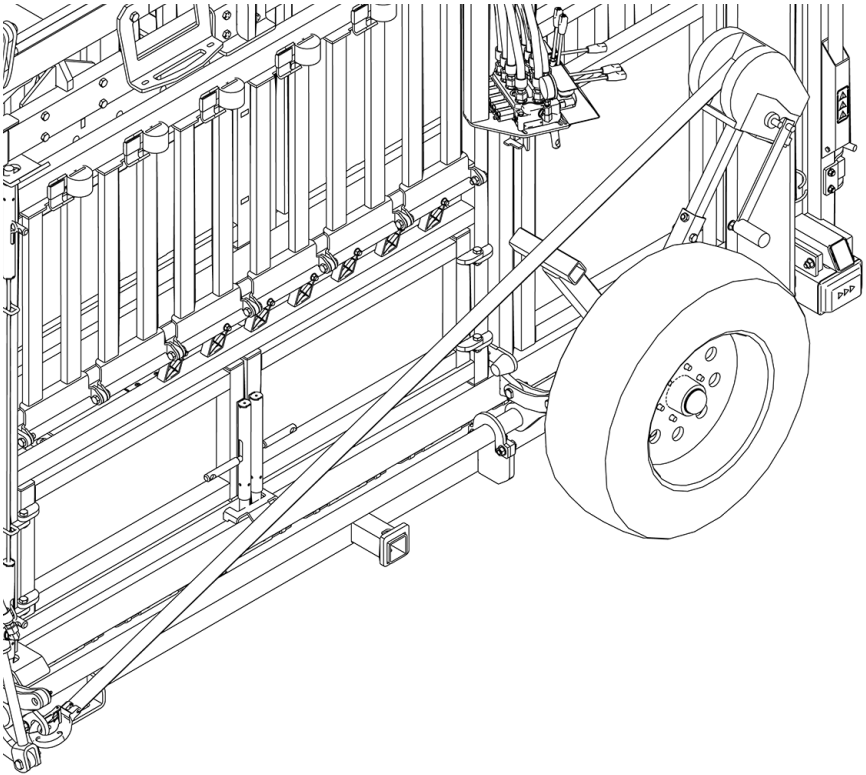

3

Starting on one side of the chute, crank the jack handle to extend the jack strap until you are able to connect the hook on the strap to the bracket located at the front of the chute, ensuring the strap is placed over the stabilizer tube.

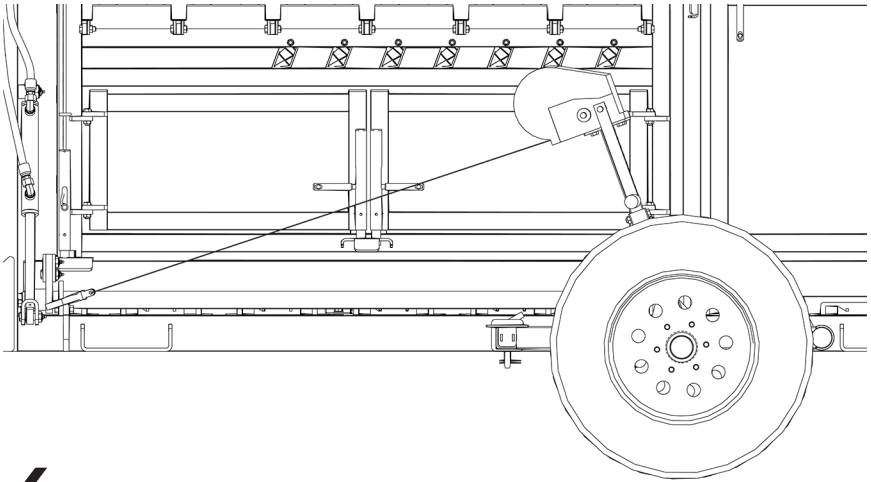

4

Crank the handle to retract the strap until it is taut, and the square wheel stabilizer tube is lined up with the front wheel mount

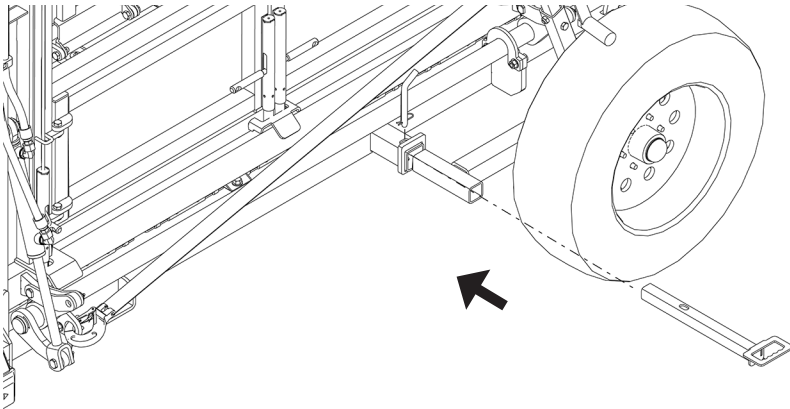

5

Insert one of the stabilizer lock bars through the stabilizer tube on the wheel and into the square front wheel mount on the chute. Secure with a transport pin and R clip.

6

Crank the winch to release the tension in the strap.

7

Repeat on the other side of the chute.

Full lift height is 14.3".

HITCH INSTALLATION:

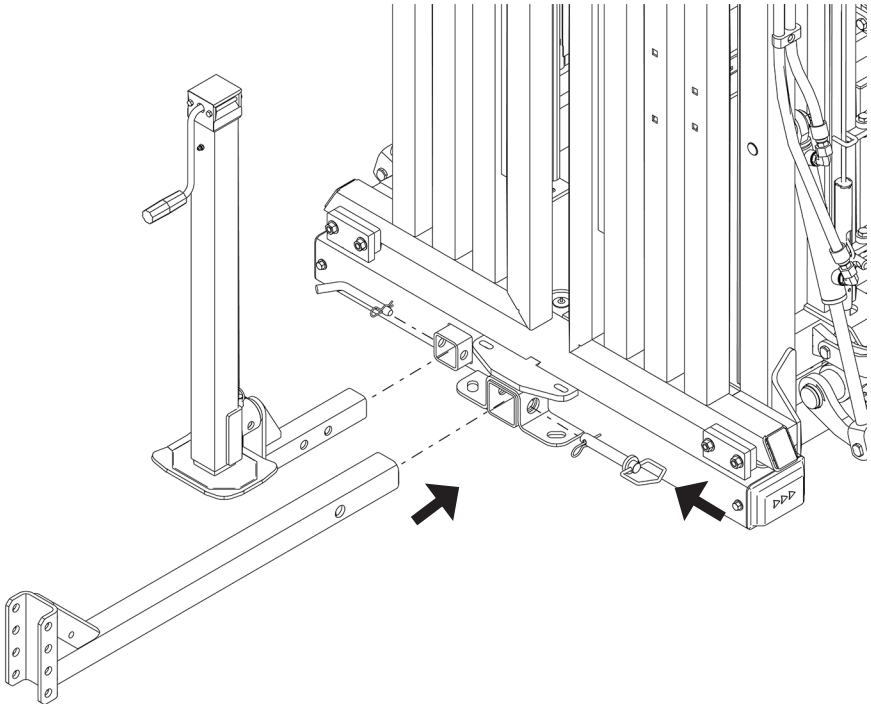

1

Insert jack and hitch into receivers on the front of the chute and secure with pins and R clips.

2

Jack the chute up until it is just high enough to be connected to your vehicle hitch, adjusting the height if necessary.

3

Connect to vehicle.

4

Retract the jack just enough so that it is no longer touching the ground.

5

Remove the R clip, pin, jack, and store safely in your vehicle for future use.



SAFETY CHECK:

- ✓ Jack is removed.
- ✓ All doors and gates are shut.
- ✓ All transport straps and pins are securely in place.
- ✓ Ensure swing arm is secured for transport.
- ✓ Tires are in good condition and attached securely.

MAXIMUM SPEED: 40 KPH / 25 MPH

WHEEL REMOVAL:



ENSURE YOU ARE DISCONNECTING THE CHUTE ON FIRM, LEVEL GROUND BEFORE PROCEEDING.

1

Re-attach jack, pin and R clip to the hitch on the front of the chute, adjusting the height if necessary.

2

Jack up the chute just enough so it can be disconnected from your vehicle.

3

Move the vehicle forward and safely out of the way.

4

Jack the chute down until the jack is retracted completely and the front of the chute is sitting fully on the ground.

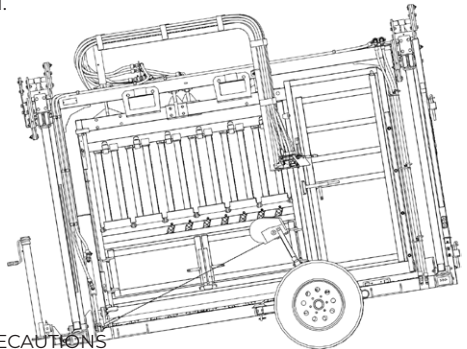

LOWERING THE CHUTE FOR USE

1

Remove the R clip, pin and stabilizer lock bar connecting the wheel to the front wheel mount and set safely aside.

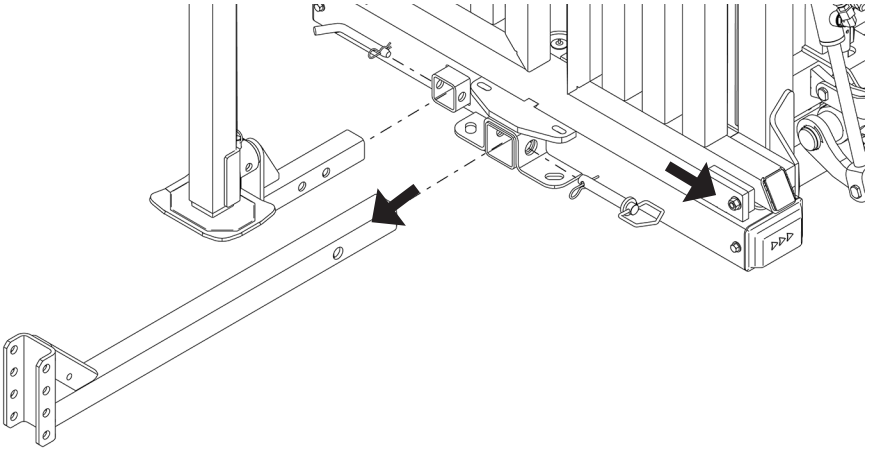

2

Remove the jack , pin and R clip and safely set aside for future use.

3

Start on one side of the chute.

4

Crank the jack until the jack strap is taught.

5

Crank the jack handle to lower the side of the chute until it is fully on the ground. Note that the other side of the chute will remain raised in the air.

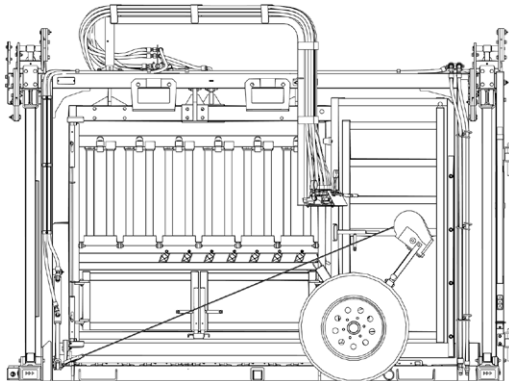

- 6** Unhook the jack strap from the bracket at the front of the chute.
- 7** Crank the jack handle to retract the jack strap until it is retracted completely.
- 8** Pull the wheel out of the rear wheel mount.
- 9** Repeat on the other side of the chute.
- 10** Ensure stabilizer lock bars, pins and R clips are inserted back into the wheels for safe storage until next use.

PREPARING THE CHUTE FOR USE

- 1** Disconnect the hydraulic swing arm from the transport position by removing the pin and R clip.

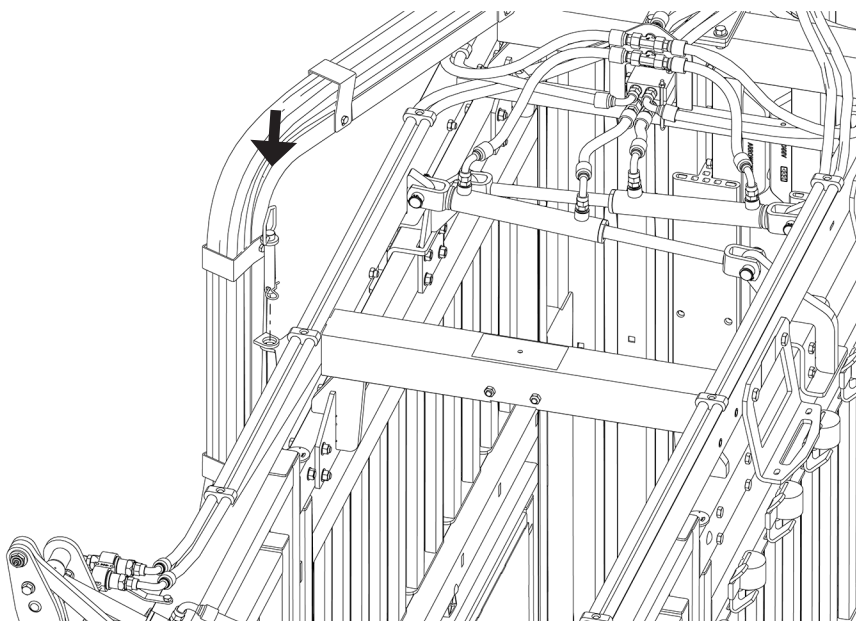

- 2** Using the side access door or drop-down panels, reconnect the hoses to the gas power pack, following the setup instructions.

3

Start the power pack to open the tail gate and remove the power pack from the chute.

4

Place power pack in desired location - farther away is best.



SAFETY CHECK:

- ✓ Inspect for damages due to transport
- ✓ Head gate and squeeze mechanisms are functioning properly
- ✓ All latches on doors, gates, and panels are functioning properly
- ✓ When applicable, ensure all add-ons are properly installed and functioning

WHEEL MAINTENANCE

It is extremely important to apply and maintain proper wheel mounting torque on your trailer wheel nuts. Torque is a measure of the amount of tightening applied to a fastener (nut or bolt) and is expressed as length force. For example, a force of 90 pounds applied at the end of a wrench on foot long will yield 90 ft. lbs. of torque. A torque wrench is the best method to assure the proper amount of torque is being applied to a fastener.

Be sure to use only fasteners matched to the cone angle of your wheel – usually 60° or 90°. The proper procedure for attaching your wheels is as follows:

1

Start all bolts or nuts by hand to prevent cross-threading.

2

Spin lug nuts all the way down until rim is seated against the wheel hub. Tighten lug nuts to 120 ft. lbs. in cross sequence.

3

Wheel nuts/bolts should be torqued before first road use and after each wheel removal. Check and re-torque after the first 10 miles, 25 miles, and again at 50 miles. Check periodically thereafter.

Maximum torque level that can be safely applied to the studs are: Stud Size: 1/2"-20 UNF, class 2A Maximum Torque: 120ft. lbs.



If you have any questions regarding your product or require assistance, please contact Arrowquip's Client Care Team at 1-877-275-6075 or by email at cs@arrowquip.com.

Printed in Canada | Updated September 2022

